

030-0875
Free-Float Flush
Mounted Paddle Handle



This flush mounted paddle handle is a redesign of our popular 030-0850 Flush Mounted Paddle Handle. Featuring a free-float paddle in the locked position, this robust product allows for power locking and is compliant to FMVSS 206 (ECE R11).

DESIGNED FOR:

- Medium to heavy-duty on-highway vehicle entrance doors where free-float locking is preferred
- Door weights of 23-455 kg (50-1000 lbs.)

FEATURES/BENEFITS:

- Provides for multiple connection points for use on inside lock and/or power lock actuation
- Inside lock provides override if paddle should be locked
- Handle can be keyed to match other TriMark door products with KeyOne™ Plus for a single-key system or provided non-locking



MATERIAL:

- Paddle and housing: Sturdy die cast zinc alloy
- Pivot components: Zinc plated, mild steel
- Bushing for paddle axle and thrust washer for pivot plate: Nylon 6/6



TriMark. Interactive. Product. Selector

Global Locations:

TriMark Corporation
500 Bailey Avenue
P.O. Box 350
New Hampton, Iowa 50659
United States
Tel: 641-394-3188
Fax: 641-394-2392
1-800-447-0343
www.trimarkcorp.com

TriMark Europe
Cedar Court
Walker road
Bardon Hill
Coalville LE67 1GZ
United Kingdom
Tel: +44(0)1530 512460
Fax: +44(0)1530 512461
www.trimarkeu.com

TriMark (Xuzhou)
Building A5 Jingwu Road
Xuzhou Economic
Development Zone
Xuzhou, Jiangsu
221004 PR China
Tel: +86 516 8773 0018
Fax: +86 516 8773 0058
www.trimarkcn.com



TriMark



TriMark Corporation



TriMark Corporation

AVAILABLE:

- Optional gasket for flange of housing is available to provide resistance to water and dirt infiltration
- Optional pivot plates (please inquire)

FINISH

- Available in a variety of finishes including black powder coated, high quality buffed chrome or a combination of black/chrome finish

INSTALLATION:

- Either hand version can be installed in a wide range of locations in door -- either horizontal or vertical orientation (left hand shown)
- Installs into current 030-0850 cut-outs

NOTE: Meets FMVSS 206 (ECE R11) locking requirements and may be used in FMVSS 206 (ECE R11) applications pending approval.

U.S. Patent No. 8,579,337

Individual part dimensions are for reference only. Refer to individual part drawings for complete dimensions, specifications, and installation procedures. Engineering assistance and application drawings are available.

Applications of this product may fall within the requirements of FMVSS 206 (ECE R11) and SAE J839 safety standards. These safety related requirements are dependent on door application, e.g. front and rear hinged doors, sliding doors, or hinged upward swinging doors. The entire door hardware system must be included in the design/analysis process: latch, handle, lock mechanism, cables/rods/linkages, fasteners, hinges, etc. This ensures compatibility of all components within the hardware system. If FMVSS 206 (ECE R11) is a requirement, then all of the components within the door system must comply with strength, inertia and locking requirements as specified within the Standard. Note that this product complies with FMVSS 206 (ECE R11) when tested in accordance with SAE J839 and that this product meets FMVSS 206 (ECE R11) locking requirements and may be used in FMVSS 206 (ECE R11) applications pending TriMark application approval.

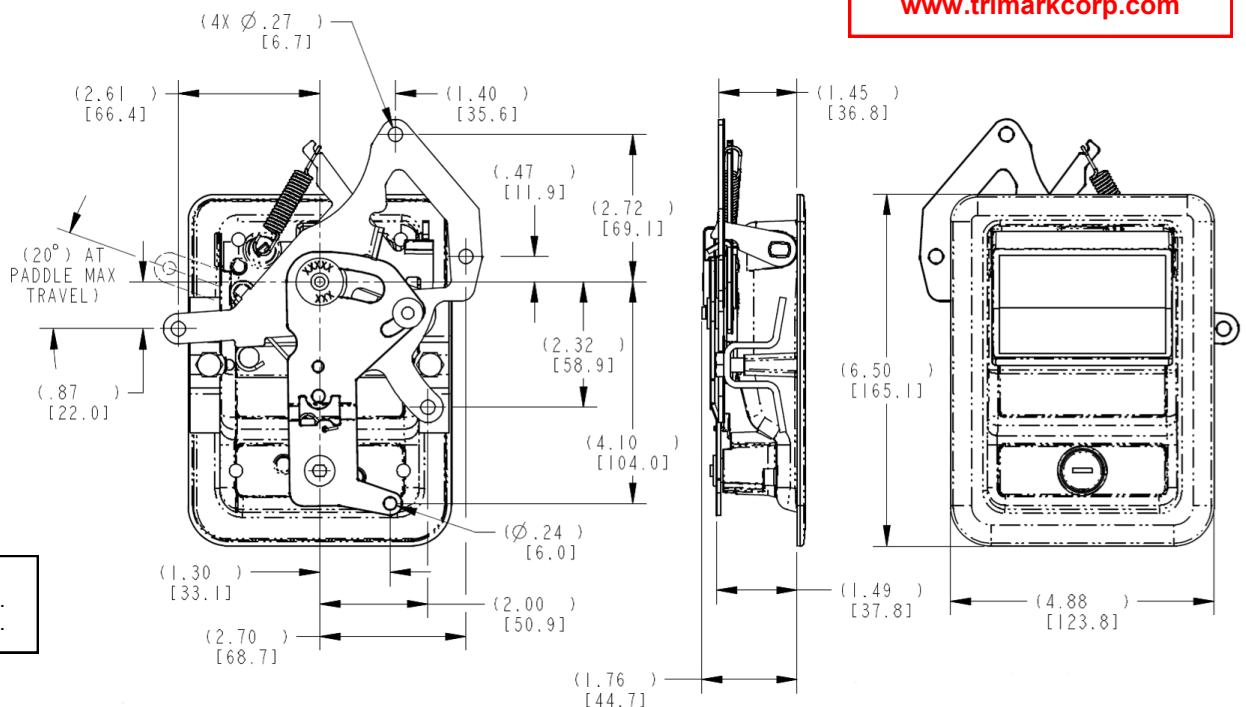
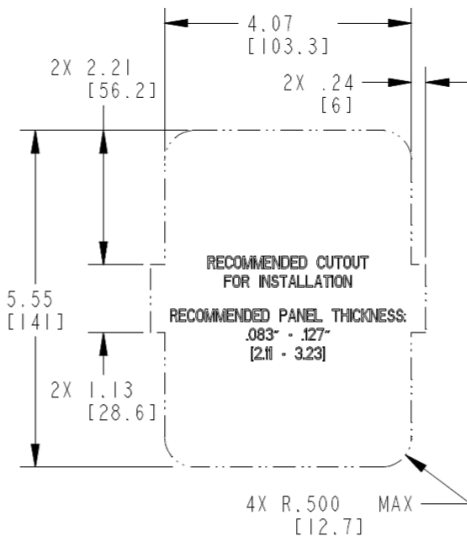

DIM A
.237" (6.02mm) Dia.
.265" (6.73mm) Dia.

For more information visit
www.trimarkcorp.com